

# Laser Welding of Engineering Plastics

Technical Information



Further information on individual products:

[www.ultramid.de](http://www.ultramid.de)

[www.ultradur-lux.basf.com](http://www.ultradur-lux.basf.com)

[www.ultrason.de](http://www.ultrason.de)

[www.plasticsportal.eu/ultraform](http://www.plasticsportal.eu/ultraform)

 **BASF**

We create chemistry

# Laser Welding of Engineering Plastics

## Overview

Laser welding of thermoplastics is a new joining technique with a host of advantages. It is not only another extremely useful welding method but also a cost-effective alternative to traditional techniques involving screws or adhesives.

Because only the region of the joint is heated and there is no mechanical stress, the process is suitable even for particularly sensitive components for example – in electronics or medical technology.

This technical information describes the principle of laser welding, some variants of the process, and also the requirements placed upon materials. Tables show which grades within the various families of polymers are suitable for the process.

## Advantages

Laser welding of thermoplastics has many advantages when compared with traditional welding methods, such as hot tool welding, vibration welding or ultrasonic welding:

- no mechanical stress on the moldings
- small amounts of heat applied to a limited area
- parts with different stiffness are weldable
- non-contact (no melt tack, no markings on moldings)
- materials of different viscosities can be welded
- virtually no erosion process
- repair welds possible

These advantages have to be weighed against the fact that welding by traditional methods is less sensitive to polymer material, processing history, pigmentation and additives. Easily the most useful modification of the process today is transmission or overlap welding.

## Process description

The joining process in laser welding is based on converting radiant energy into heat via its absorption within the material, giving local melting in the joining region (Fig. 1). The basic requirement for the transmission process is therefore a suitable combination of materials.

The short-wavelength IR radiation is intended to pass virtually unhindered through the upper transmitting joint component and become completely absorbed at a depth of from 0.1 to 0.5mm within the lower joint component, becoming converted into heat (1). This joint component is heated and melted in the absorption region by the energy supplied (2). Melting increases the volume and bridges the joint gap. Contact enables heat transfer between the two joint components (3). The laser-transmitting joint component also melted by conducted heat (4).

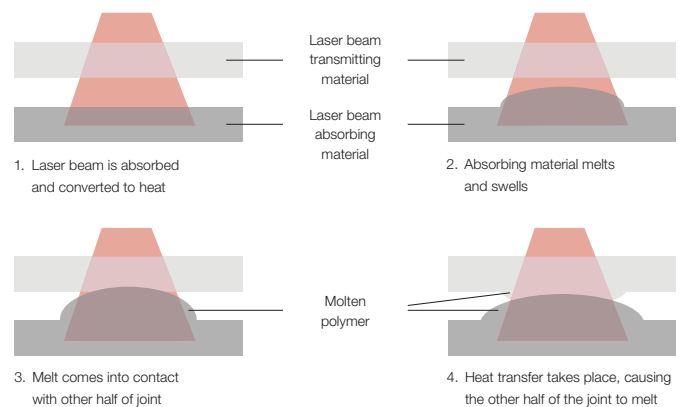

Fig. 1: Schematic description of the transmission welding process

## Radiation sources (lasers) and optical properties of polymer materials

Intensity of absorption is determined by the material and also by its additives, as well as by the wavelength emitted by the laser source. The radiation optics of the materials can be controlled as required within certain limits by modifying the materials appropriately. Absorption spectra give information on the conversion of incident energy as a function of wavelength. Reflectance and transmittance are given as a function of wavelength in reflection and transmission spectra (Fig. 2).

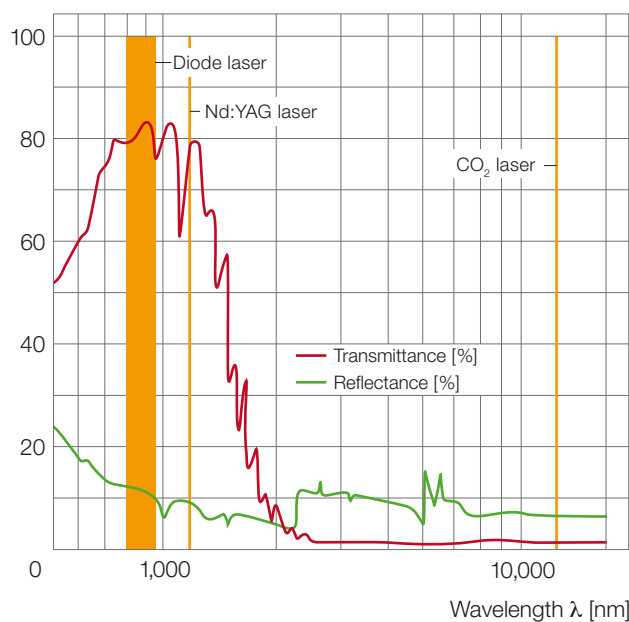

Fig. 2: Reflection and transmission spectra for an Ultramid® A sheet of 2 mm thickness

The degree of transmission required means that the main radiation sources (Fig. 2) for transmission welding of plastics are those emitting in the short-wavelength infrared:

- solid-state lasers (Nd:YAG laser,  $\lambda = 1,064$  nm), and
- high-power diode lasers ( $\lambda = 800$ -1,000 nm).

Medium- and long-wavelength IR radiation is completely absorbed close to the surface of all polymers, whatever their content of fillers or additives. This means that CO<sub>2</sub> lasers ( $\lambda = 10,600$  nm) are restricted to film welding.

The latest generation of high-power diode lasers features compactness, cost-effectiveness and high efficiency, but these lasers have limited focusing capability and are therefore not suitable for every modification of the process.

## Variables and significant process parameters

Low-absorption thermoplastics have good suitability for laser welding if they are combined with an absorbing and chemically compatible material. The laser power and laser-permeable material for transmission welding therefore need to be selected to make the transmitted energy density of the laser beam sufficient to melt the absorbing material.

The depth to which the laser beam penetrates the plastic depends on a wide variety of variables (Fig. 3) such as

- wavelength of the laser beam
- chemical composition
- morphology, and
- the nature and amount of additives (fibers, colorants, plasticizers and fillers).

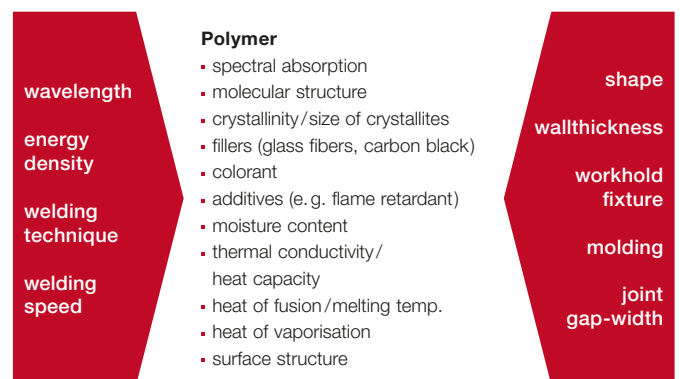

Fig. 3: Factors affecting depth of penetration of laser beam into plastic and the joint quality

### Morphology

Amorphous thermoplastics absorb only a small proportion of the incident laser beam, and theoretical penetration depths of 100mm and more can therefore be achieved. The optical properties of semi-crystalline thermoplastics are quite different: the secondary crystalline structures present (e.g. spherulites) scatter the laser beam.

### Fillers and reinforcing materials

Engineering plastics generally have fillers and reinforcing materials, which can scatter or even absorb incident IR radiation. Although glass fibers themselves are permeable to IR radiation, scattering of radiation at the many interfaces between the fibers and the matrix increases the optical path and thus reduces transmission.

In colored plastics the content of pigment or dye plays an important role. The lower the penetration depth, the greater is the risk of damage to the material. At lower pigment contents, relatively deep melting of the absorbing joint part is likely to be possible without thermal damage to a material. The resultant increase in volume expansion lengthens the period of melt contact and thus increases weld strength. Absorption and transmission behavior can therefore be adapted by incorporating fillers and/or pigments – even to the extreme of surface absorption within a layer just a few micrometers thick.

Controlled incorporation of specific additives can produce colored plastics, which to the eye appear identical but actually have the different absorption behavior needed for transmission welding.

### Process parameters

To achieve a good quality weld it is necessary to operate within the maximum and minimum limits for the feed rate and laser power. Since the diffusion process required for welding requires a certain period for the high temperatures to act, problems will result if the feed rate is too high or the laser power too low. On the other hand, decomposition of the material can result if the feed rate is too low or the laser power too high.

## Suitable materials

Amorphous thermoplastics like PSU often show ideal transmission properties in the wavelength region usually used. In contrast semi-crystalline thermoplastics such as PA, PBT and POM can absorb and reflect a considerable proportion of the laser energy even without additives (Table 1).

	Optical properties	Welding characteristics
Ultramid® (PA)	+	++
Ultradur® (PBT)	o	+
Ultraform® (POM)	+	++
Ultradur® LUX (transmission-optimized PBT)	+	++
Ultrason® S (PSU)	++	++

++ = very good, + = good, o = satisfactory

Table 1: Suitability of various thermoplastics for laser welding

## Process variations

Nowadays a number of modified processes are available. These are all based on the transmission principle, and the requirements of each case determine which modification is most useful (Table 2). The processes are described below together with their typical features.

### Contour welding

Contour welding is a sequential welding process in which either the laser beam is guided along a freely programmable weld profile or the component is moved relative to a fixed laser (Fig. 4). For this process modification there are fiber-coupled laser systems with a rounded beam cross section. Depending on the type of laser and the optics, the width of the weld can be varied between tenths of one millimeter and several millimeters.

The process can weld components with complex, three-dimensional joint contours. It also allows rapid changeover between components of different shapes.

Since the melting of the weld takes place sequentially, no melt flow-out is permissible, and this modification therefore requires a small joint gap.

### Simultaneous welding

In simultaneous welding, radiation from individual high-power diodes is emitted in the shape of a line arranged along the contours of the seam to be welded (Fig. 5). The entire profile is therefore molten and welded simultaneously. The number of diodes required depends on the dimensions of the component and on the welding power needed.

The process requires no relative movement between component and laser beam, and there is no need for any system for guiding the beam. On the other hand, a new arrangement of laser diodes or a new welding tool is needed for each change of weld profile or design, and the shape of the weld is currently still restricted to profiles composed of straight lines.

Melt flow-out can be produced by applying pressure to the weld profile during the welding process. This can compensate for distortion, component tolerances or cavities in the region of the weld.

Simultaneous welding features very short process times and is therefore particularly suitable for mass production.

### Quasi-simultaneous welding or scan welding

Quasi-simultaneous welding is a combination of contour welding and simultaneous welding. Galvanometric mirrors (scanners) are used to guide the laser beam along the weld profile at a very high speed of 10 m/s or more (Fig. 6). The high speed of transit gives progressive heating and melting of the region to be welded. Unlike with simultaneous welding, there is high flexibility for changes in weld profile.

The application of quasi – simultaneous welding is restricted to components with dimensions of not more than 200x200mm and virtually planar weld profiles. As with simultaneous welding, pressure can be applied during the welding process to make the melt compensate for molding tolerances. Process times are longer than with simultaneous welding, but shorter than for contour welding. The use of long deflection paths and scanner mirrors demands a laser source with high beam quality. Nd:YAG lasers are therefore used.

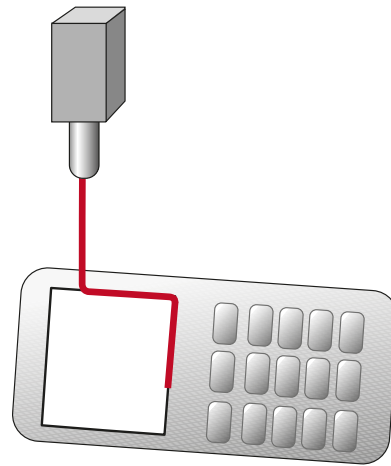

Fig. 4: Schematic of contour welding

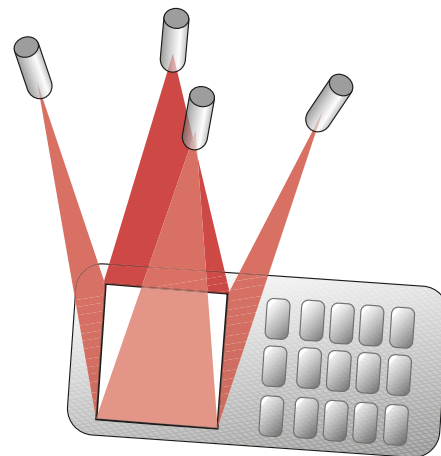

Fig. 5: Schematic of simultaneous welding

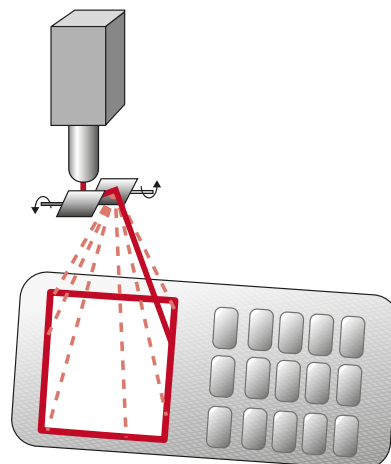

Fig. 6: Schematic of quasi-simultaneous welding

### Mask welding

Mask welding is the newest process. A linear laser beam is made to traverse the parts to be joined and a mask is used to screen specific areas from the beam, so that it impacts the jointing surface only at the areas to be welded (Fig. 7). The process can produce very precisely positioned welds.

Very fine structuring of the mask can be used to achieve extremely high resolution, and welds just 10  $\mu\text{m}$  in width can be produced. Straight and curved lines of various widths can be produced in a single operation, and sheets can also be welded. This modification of the process is therefore used mainly for sensors, chips, electronic components or micro-system technology. However, changes in the shape of the weld require production of a new mask.

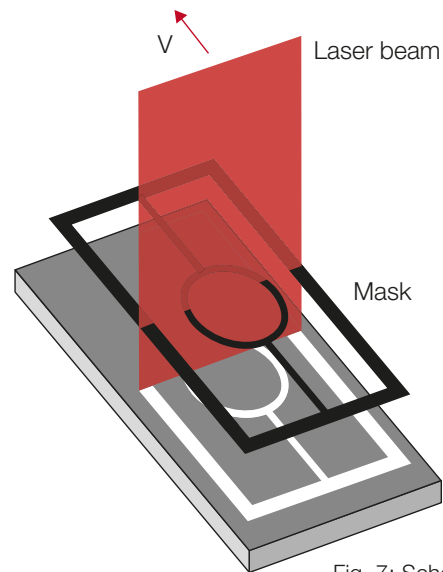

Fig. 7: Schematic of mask welding

	Contour welding	Simultaneous welding	Quasi-simultaneous welding	Mask welding
Flexibility	very high	low	high	low
Welding time	long	short	moderate	moderate-long
Complexity of weld profile	very high	moderate	high	moderate
Tolerance compensation	none	possible	possible	none
Plant cost	moderate	very high	high	moderate-high
Usable laser type	Nd:YAG; diode	diode	Nd:YAG	diode

Table 2: Comparison of process variants for laser welding

### Safety and the environment

When correct procedures are used to weld polymeric materials the amounts of gaseous emissions produced are generally very small. Nevertheless, installation of adequately sized extraction and filtration systems is recommended, since alongside the main constituents of the exhaust gases – the non-hazardous  $\text{CO}_2$  and  $\text{H}_2\text{O}$  – small concentrations of toxic constituents can be present.

The handling of lasers must always comply with appropriate regulations – such as those relating to employee safety requirements – since even scattered radiation from a laser can damage eyes and skin.



## Selected Product Literature:

- Ultramid® – Product Brochure
- Ultramid® – Product Range
- Ultradur® – Product Brochure
- Ultradur® – Product Range
- Ultraform® – Product Brochure
- Ultraform® – Product Range
- Ultrason® E, S and P – Product Brochure
- Ultrason® E, S and P – Product Range
- Ultramid®, Ultradur® and Ultraform® – Resistance to Chemicals
- Ultrason® – Resistance to Chemicals
- Ultradur® LUX – PBT for Laser Welding

### Note

The data contained in this publication are based on our current knowledge and experience. In view of the many factors that may affect processing and application of our product, these data do not relieve processors from carrying out own investigations and tests; neither do these data imply any guarantee of certain properties, nor the suitability of the product for a specific purpose. Any descriptions, drawings, photographs, data, proportions, weights etc. given herein may change without prior information and do not constitute the agreed contractual quality of the product. It is the responsibility of the recipient of our products to ensure that any proprietary rights and existing laws and legislation are observed. (April 2016)

### Please visit our websites:

[www.plasticsportal.com](http://www.plasticsportal.com) (World)

[www.plasticsportal.eu](http://www.plasticsportal.eu) (Europe)

### Additional information on specific products:

[www.plasticsportal.eu/name of product](http://www.plasticsportal.eu/name_of_product)

e. g. [www.plasticsportal.eu/ultradur](http://www.plasticsportal.eu/ultradur)

### Request of brochures:

PM/K, F204

Fax: +49 621 60-49497

If you have technical questions on the products,  
please contact the Ultra-Infopoint:

